

# Dieter's Nixie Tube Data Archive

This file is a part of Dieter's Nixie- and display tubes data archive

If you have more datasheets, articles, books, pictures or other information about Nixie tubes or other display devices please let me know.

Thank you!

Document in this file	Raytheon CK6909 Dekatron Tube Datasheet Dated 1960
Display devices in this document	CK6909

# Technical Information

## CK6909

### DECADE COUNTER

The CK6909 is a cold cathode gas-filled 100 KC high speed bi-directional ring stepping decade counter tube. This type features direct visual neon glow readout on any of the ten radially spaced cathodes or electrical output in the form of a voltage from cathode numbers 0, 5, 8, and 9. Negligible power dissipation, short resolution time, simple low cost circuitry, and no moving parts make this a very reliable counter device. Some of the many uses for this type include; counting, timing, sampling, frequency dividing, coding, matrixing, telemetering, and controlling.

#### ELECTRICAL DATA

##### RATINGS—ABSOLUTE MAXIMUM VALUES:

Total Anode Current	1.2 Ma
Voltage Between Electrodes (Excluding Anode)	140 volts
Supply Voltage (Anode to Cathode)	400 volts
Input Frequency	100,000 cps

##### CHARACTERISTICS AND TYPICAL OPERATION:

DC Supply Voltage	450 volts
Anode Resistor	0.27 megohms
Nominal Tube Drop	235 volts
Cathode Resistor	24 Kohms
Output Voltage (Across Cathode Resistor)	15 volts

#### MECHANICAL DATA

ENVELOPE ..... T-9 Glass  
 BASE ..... Intermediate Shell  
 Octal 8-Pin  
 MOUNTING POSITION ..... Any  
 (Visual Readout from  
 Top of Tube)  
 ZERO POSITION ..... Cathode #0  
 (Aligned With Pin  
 #6 ± 10°)

#### PHYSICAL DIMENSIONS

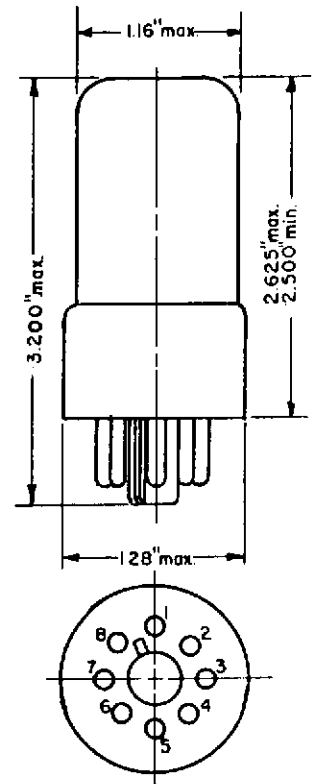

#### TERMINAL CONNECTIONS:

- Pin 1 Common Cathodes
- Pin 2 Cathode #5
- Pin 3 Guide 1
- Pin 4 Anode
- Pin 5 Guide 2
- Pin 6 Cathode #9
- Pin 7 Cathode #0
- Pin 8 Cathode #8



# CK6909

## DECADE COUNTER

### APPLICATION NOTES

#### CONSTRUCTION

The Raytheon decade counter tube consists of thirty (30) thin rod shaped cathodes surrounding a circular anode, all of which are set in a glass envelope employing rare gases at low pressure. The thirty (30) cathodes are identical in construction and are radially spaced concentric to the anode. The cathodes are connected in groups of threes; main cathode, guide 1 cathode and guide 2 cathode. The guide 1's are connected together internally and are brought out to one of the base pins. The guide 2's are similarly connected and brought out to another base pin. The main cathodes may be brought out individually or connected in groups depending on the tube type. Conduction occurs between the anode and the most negative cathode pin causing an orange colored glow at the tip of that cathode. This glow can be viewed from the top of the tube or may be read as a voltage developed across a cathode resistor.

#### OPERATION

In operation the main cathodes are at a more negative potential than the guide pins. When a negative input pulse (more negative than the cathode) is applied to guide 1 the glow is transferred from the initial cathode (K0) to guide 1. A similar pulse applied to guide 2 transfers the pulse to guide 2. When the potential of guide 2 returns to a value more positive than the main cathodes the glow transfers to the next closest main cathode. In order to insure reliable operation the phase relationship between pulses should be such that the pulse to guide 2 should overlap the pulse to guide 1. This overlap should have a minimum value of 10 microseconds for medium speed tubes and 2 microseconds for high speed tubes. Typical wave shapes are shown in figure 1 for a high speed tube.

#### RESETTING

Usually the counting in a decade counter tube starts from a particular initial main cathode, and after the completion of a count it is desired to return the glow to the initial cathode. This may be accomplished two ways, (1) by opening the negative connection to all main cathodes and guides except the zero cathode, or (2) by pulsing the zero cathode 120-180 volts negative. Either method should cause the zero cathode to become 120 to 180 volts negative with respect to all other cathodes. It may become necessary in certain applications to reset the glow at such a speed so as not to lose count. Therefore, it is recommended that the reset pulse width be the same as the count signal pulse width received from the drivers. When several tubes are used in cascade the reset for the first tube should be such that it is made to the zero cathode.



CK6909

DECADE COUNTER

APPLICATION NOTES (Cont'd.)

RESETTING (Cont'd)

The succeeding tubes should be set for the number 9 cathodes in order to account for the pulse passed to these tubes when the preceding tubes are reset. This procedure will position the glow at all zero cathodes when the reset is complete.

DRIVE CIRCUITS

The circuit shown in figure 2 is that of a typical 0-30 KC medium speed drive circuit. The RC integrator network causes a delayed pulse to guide 2 and allows the initial pulse to be applied directly to guide 1. This allows a single negative pulse to step the glow instead of incurring the expense of generating two separate pulses. When the glow steps to the zero cathode (K<sub>0</sub>) an output pulse in the form of a negative voltage is developed across the 100K cathode resistor. This pulse may then be used as the input pulse to a succeeding drive circuit. The order in which guide 1 and guide 2 receive the input pulses determines the direction of rotation of the neon glow.

Figure 3 is that of a typical 0-100 Kc high speed drive circuit. The sinewave input is fed directly to one side of the 5814 amplifier tube and hence to the 1st guide electrode. The other guide electrode is fed from the same input waveform but it is first passed through a phase changing network. This is an active filter using one section of another 5814. The tube provides a 180° phase shift which is increased to 270° by the small 10 uuf capacity. This waveform then mixes with the signal input to provide a resultant sinewave of the same fundamental frequency as the input but with a phase lag. This lag is sufficient to permit consistent operation of the counter tube.

## DECADE COUNTER

FIGURE 1

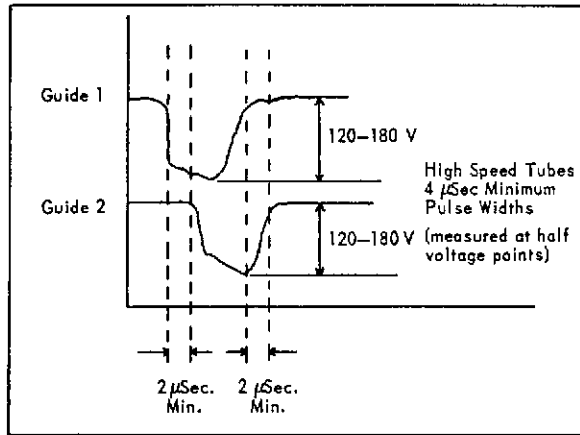

FIGURE 2

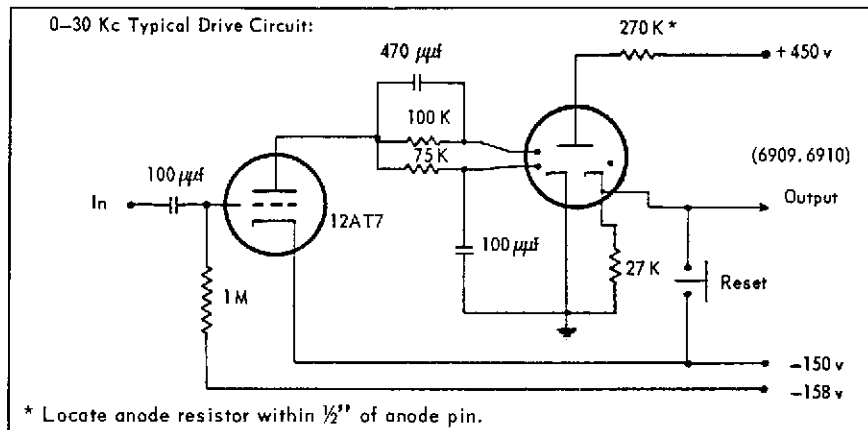

FIGURE 3

